

2021/0153/RG3 – 394 High Street, Lincoln, LN5 7SS

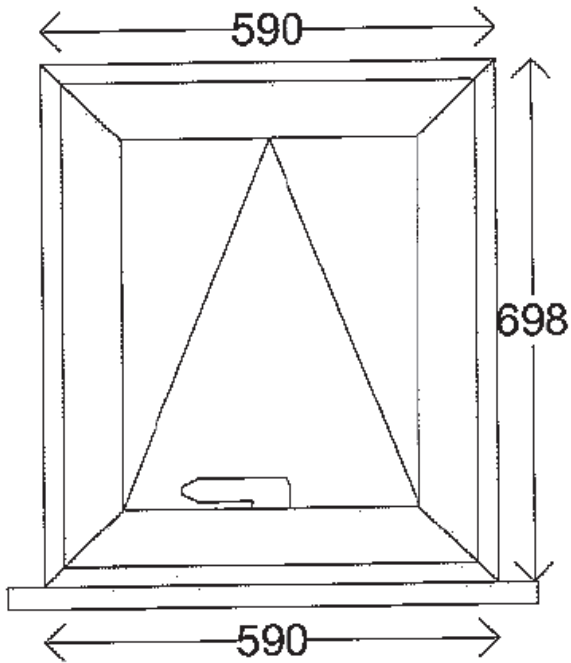

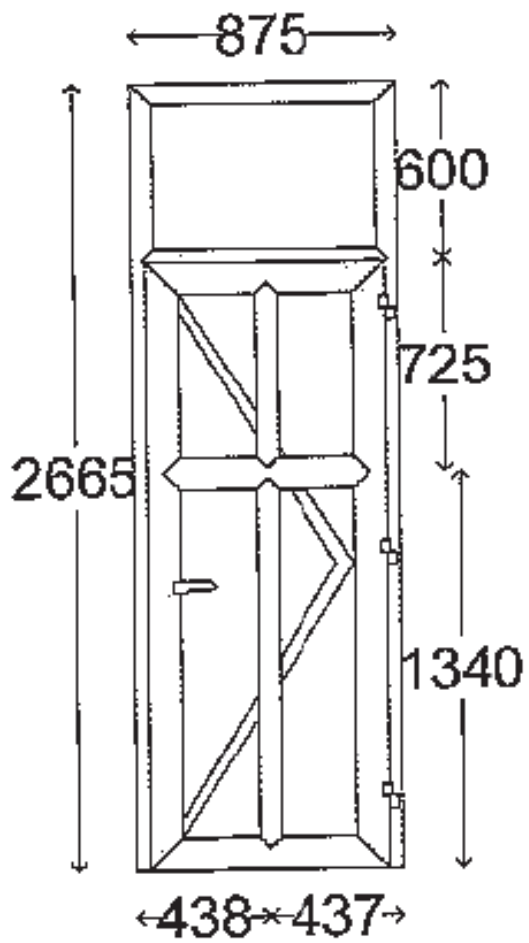

Photographs







Consultation Responses

Consultee Details

Name: Ms Catherine Waby

Address: St Mary's Guildhall, 385 High Street, Lincoln LN5 7SF

Email: Not Available

On Behalf Of: Lincoln Civic Trust

Comments

NO Objection

Comment It would appear that there are two windows adjacent to each other at the rear and the one being replaced will of a totally different design to the other and hence suggest that either the other is changes in the same design or it should be redesigned to match the other window.



Warren Peppard
Head of Development Management
Lincolnshire County Council
County Offices
Newland
Lincoln LN1 1YL
Tel: 01522 782070
HighwaysSUDsSupport@lincolnshire.gov.uk

To: Lincoln City Council

Application Ref: 2021/0153/RG3

Proposal: **Replacement of 1 Timber rear door to UPVC and replacement of 2 Timber rear windows to UPVC.**

Location: **394 High Street, Lincoln, Lincolnshire, LN5 7SS**

With reference to the above application received 25 March 2021

Notice is hereby given that the County Council as Local Highway and Lead Local Flood Authority:

Does not wish to restrict the grant of permission.

CONDITIONS (INCLUDING REASONS) /REASONS FOR REFUSAL

NO OBS

Having given due regard to the appropriate local and national planning policy guidance (in particular the National Planning Policy Framework), Lincolnshire County Council (as Highway Authority and Lead Local Flood Authority) has concluded that the proposed development is acceptable and accordingly, does not wish to object to this planning application.

Case Officer:
John Clifton
for Warren Peppard
Head of Development Management

Date: 12/04/2021